

**Veterinary Medicines  
Guidance Note**

**Medicated  
Feedingstuffs and  
Specified Feed  
Additives**

**No 22** *Last updated September 2009*



**ASSURING THE SAFETY, QUALITY AND EFFICACY  
OF VETERINARY MEDICINES**



**THESE NOTES ARE ONLY A GENERAL GUIDE AND MUST NOT BE TREATED AS A COMPLETE OR AUTHORITATIVE STATEMENT OF THE LAW ON ANY PARTICULAR CASE**

**VETERINARY MEDICINES DIRECTORATE**

**WOODHAM LANE, NEW HAW, ADDLESTONE, SURREY KT15 3LS**

**Telephone: +44 (0)1932 336911 Fax +44 (0)1932 336618**

**E-mail [VMGNotes@vmd.defra.gsi.gov.uk](mailto:VMGNotes@vmd.defra.gsi.gov.uk) [www.vmd.gov.uk](http://www.vmd.gov.uk)**



**INVESTOR IN PEOPLE**

**TABLE OF CONTENTS**

<b>CONTENTS</b>	<b>PARAGRAPH</b>	<b>PAGE</b>
<b>INTRODUCTION</b>	<b>1</b>	<b>3</b>
<b>APPROVAL</b>	<b>5</b>	<b>3</b>
<b>Animals on Domestic Premises</b>	<b>11</b>	<b>4</b>
<b>ADDITIONAL DUTIES IN RELATION TO VETERINARY MEDICINAL PRODUCTS</b>	<b>12</b>	<b>5</b>
<b>DISTRIBUTORS</b>	<b>17</b>	<b>5</b>
<b>MEDICATED FEEDINGSTUFFS PRESCRIPTIONS (MFSP)</b>	<b>21</b>	<b>6</b>
<b>LABELS</b>	<b>24</b>	<b>6</b>
<b>CONTAINER/PACKAGES</b>	<b>31</b>	<b>7</b>
<b>RECORD KEEPING</b>	<b>32</b>	<b>8</b>
<b>IMPORTATION OF MEDICATED FEEDINGSTUFFS FROM MEMBER STATES</b>	<b>34</b>	<b>8</b>
<b>IMPORTATION FROM THIRD COUNTRIES</b>	<b>35</b>	<b>8</b>
<b>IMPORTATION OF VETERINARY MEDICINAL PRODUCTS FOR EXPORT ONLY</b>	<b>37</b>	<b>8</b>
<b>DISPOSAL OF FEED PRODUCTS</b>	<b>38</b>	<b>9</b>
<b>POSSESSION</b>	<b>39</b>	<b>9</b>
<b>NON-COMPLIANCE</b>	<b>40</b>	<b>9</b>
<b>FURTHER INFORMATION</b>	<b>42</b>	<b>9</b>
<b>ANNEX II OF EU REGULATION 183/2005</b>	<b>ANNEX A</b>	<b>11</b>
<b>WHO CAN SELL WHAT TO WHOM</b>	<b>ANNEX B</b>	<b>17</b>

## INTRODUCTION

1. This is one of a series of Veterinary Medicine Guidance (VMG) notes explaining the requirements under the Veterinary Medicines Regulations ('the Regulations'). The Regulations are revoked and replaced every year, so the references to them should be read as referring to the ones that are currently in force. Therefore, the date and number of the Statutory Instrument are not shown in this VMG Note. The VMG Notes will be updated as necessary and the date of the most recent update is shown on the front cover.
2. The Regulations set out the UK controls on veterinary medicines, including their manufacture, advertising, marketing, supply and administration. VMG Note 1: An Introduction to Marketing Controls on Veterinary Medicines gives basic information about the scope of the Regulations and the requirements for Marketing Authorisations (MAs).
3. This VMG Note describes the requirements for the manufacture and supply of veterinary medicinal products (VMPs) for incorporation into animal feedingstuffs, specified feed additives (SFAs) (e.g. products authorised under Regulation 1831/2003), premixtures, feedingstuffs containing SFAs and VMPs as implemented in Schedule 5 of the Regulations.
4. Within the scope of the Regulations, this VMG Note covers SFAs, that is, coccidiostats, histomonostats and certain other zootechnical additives, e.g. non-antibiotic growth promoters. All other additives are the responsibility of the Food Standards Agency and are covered by separate legislation and guidance, which is available from [www.foodstandards.gov.uk](http://www.foodstandards.gov.uk). The Regulations also cover veterinary medicinal products (VMPs) where the MA specifies that they may be incorporated into feedingstuffs.

## APPROVAL

5. Feed business operators that manufacture, intend to manufacture or supply SFAs, or premixtures or feedingstuffs that contain SFAs or VMPs must be approved by the Secretary of State before they can undertake any such activity. However there are exemptions as described in paragraph 11. Before they can be approved, all feed business operators must meet the applicable criteria set out in Annex II to Regulation EC/183/2005, which is reproduced in Annex A to this VMG Note.
6. One of these requirements is that feed business operators carrying out activities under Annex II of 183/2005 must apply Hazard Analysis and Critical Control Points (HACCP) systems. HACCP provides a standard way to monitor products and assess risks at specified points in the manufacture of these substances.

7. Such feed business operators include feed compounders that produce protein concentrates or balancer meals incorporating VMPs or SFAs at levels that exceed the maximum permitted in the complete feed. Under the Regulations such an activity is the production of premixtures and the feed business operator must therefore apply to the Animal Medicines Inspectorate (AMI) of the VMD for categorisation as a premixture manufacturer.
8. On the other hand, on-farm mixers producing balancer feeds for use with, for example, liquid co-products are considered as producing complete feeds, provided that they are produced for their own use only. Such on-farm mixers can be considered to be feed producers.
9. All feed business operators, except those referred to in paragraphs 11 and 15, are inspected to ensure that they comply with the Regulations. The frequency of inspection depends on the nature of the feed business operator and will take account of a risk analysis.
10. The Secretary of State will charge fees to the industry for the inspections undertaken. The charges reflect the different responsibilities of each type of manufacturer and distributor and take account of the frequency and complexity of inspections. A table of categories of manufacturers and distributors is at Annex B.

### ANIMALS ON DOMESTIC PREMISES

11. Where a person incorporates a VMP into feedingstuffs in domestic premises for feeding on those premises:
  - a) non food producing animals or
  - b) food producing animals kept purely for domestic consumption,the premises are exempt from the requirement to be approved by the Secretary of State to incorporate VMPs into feedingstuffs.

A registered Suitable Qualified Person may supply a premixture containing a veterinary medicinal product, or feedingstuffs containing a veterinary medicinal product, to such a producer providing that

- (a) in the case of premixture, the amount of premixture is intended to be mixed into a final feed not exceeding 30 kg, and
- (b) in the case of feedingstuffs, the pack weight does not exceed 30 kg.

In such cases the prescription may be made orally. However, if the prescription is not in writing, the VMP may only be supplied by the person who prescribed it, and should give advice on any contra-indications and warnings specified in the Summary of Product Characteristics (SPC).

### ADDITIONAL DUTIES IN RELATION TO VETERINARY MEDICINAL PRODUCTS

12. Additional requirements for the manufacture of premixtures and feedingstuffs containing VMPs are detailed in Directive 90/167/EC.
13. A person who incorporates a VMP into a premixture must incorporate it in accordance with the SPC or the product label, and must take account of any interactions listed there.
14. In accordance with Schedule 5 of the Regulations, any person who incorporates a VMP into a premixture or feedingstuff must ensure that the VMP does not contain the same active substance as any other additive already incorporated, or to be incorporated, into that premixture or feedingstuff.
15. An exception can be made when preparing a feed which is to contain zinc in any form. In order to avoid toxicity, the total amount of zinc in the final feed must comply with the authorised maximum dosage stated in the MA of any VMP used to prepare the premixture or feedingstuff.
16. A person who incorporates a VMP into a feedingstuff:
  - (i) must incorporate it in accordance with the SPC, or the product label and must take account of any interactions listed there;
  - (ii) must ensure that the VMP does not contain the same active substance as any other additive;
  - (iii) must ensure that the VMP is incorporated in accordance with its marketing authorisation (unless it has been prescribed under the cascade) and the prescription;
  - (iv) must ensure that the daily dose of the VMP is contained in a quantity of medicated feedingstuffs (MFS) corresponding to at least half the daily feedingstuffs ration of the animals treated, or, in the case of ruminants, corresponding to at least half the daily requirements of non-mineral supplementary feedingstuffs.

### DISTRIBUTORS

17. A distributor is a feed business operator who is approved to store, supply, wrap or package SFAs and premixtures and feedingstuffs containing SFAs. Distributors are also approved to store and supply premixtures and feedingstuffs containing VMPs. They must meet the criteria set out in the storage, transport, record keeping, complaints and product recall sections of Annex A to this VMG Note. However, it should be noted that a distributor may not retail VMPs.
18. Approval as a feedingstuffs manufacturer (other than category 6 or 7) only permits the supply of that manufacturer's own product. Manufacturers who also

## MEDICATED FEEDINGSTUFFS AND SPECIFIED FEED ADDITIVES

supply SFAs, premixtures containing VMPs or SFAs or medicated feedingstuffs, require additional approval as Distributors. However, in such cases, the business is only required to pay the higher fee plus 75% of the lower fee.

19. Distributors who act purely as traders and do not hold products on their premises are exempt from on-site visits and inspections. They must still register with the Secretary of State and supply documents detailing their sales records of these products on request.
20. A toll manufacturer is a manufacturer who provides a manufacturing service on behalf of another, to that manufacturer's specific request to specific specifications and formulation (Contract manufacturing). Only toll manufacturers are permitted to supply another manufacturer in this way without being approved as a distributor.

### MEDICATED FEEDINGSTUFFS PRESCRIPTIONS (MFSp)

21. With the exception of anthelmintics (wormers), VMPs for incorporation into animal feedingstuffs are classified as POM-V. MFS containing POM-V medicines can only be supplied to the keeper of animals on receipt of an MFSp prescription (MFSp) issued by a veterinary surgeon. MFS may be supplied to an approved commercial manufacturer or distributor without a prescription.
22. MFS containing anthelmintics classified as POM-VPS can also only be supplied to the keeper of animals on receipt of an MFSp. However, these may be prescribed by a veterinary surgeon, a pharmacist or a Suitably Qualified Person (SQP).
23. The MFSp must contain the details listed in Schedule 5 of the Regulations. There is further information in VMG Note 21: *Medicated Feedingstuffs Prescriptions*. For information on distribution categories see VMG Note 3: *Marketing Authorisations for Veterinary Medicinal Products – Distribution Categories*.

### LABELS

24. Labels must be clear, legible and indelible and be written in English. They may also contain other languages but the information in each language must be the same.
25. Authorisations for additives and veterinary medicinal products (VMPs) stipulate the usable life for feedingstuffs into which they have been incorporated. Where more than one additive or VMP is incorporated into a feedingstuff the shortest in-feed shelf life must be observed and must be shown on the label.
26. Authorisations for additives and veterinary medicinal products (VMPs) stipulate the withdrawal period which must be shown on the label.

The withdrawal period must be that specified in the marketing authorisation for the VMP or as specified in the prescription if this is a longer period.

If there is more than one VMP used the withdrawal period must be the longest period specified in any of the marketing authorisations for the VMPs or as specified in the prescription if this is longer.

If there is no prescription at the time of labelling it must be in accordance with the marketing authorisation (or the longest period if there is more than one marketing authorisation) but the label must also state "If the prescription specifies a longer withdrawal period this must be applied".

27. Labelling requirements for additives and premixtures of additives are covered by directly applicable EU legislation (Regulation 1831/2003) and therefore are not in the Regulations. For ease of reference, the applicable provisions are listed here:
- (a) the name of the functional group of the product followed by the authorised name of the additive;
  - (b) the name or business name and address of the person responsible for placing the product on the market;
  - (c) the net weight or, in the case of liquid additives and premixtures, either the net volume or the net weight;
  - (d) where appropriate, the establishment approval number;
  - (e) directions for use, any safety recommendations and, where applicable, the specific requirements mentioned in the authorisation, including the animal species and categories for which the additive or premixture of additives is intended;
  - (f) the identification number of the additive;
  - (g) the batch reference number and date of manufacture.
28. In the case of a product manufactured by a toll manufacturer, the approval number of the toll manufacturer and the name and address of the receiving manufacturer must appear on the label.
29. Additives belonging to a functional group specified in Annex III of Regulation 1831/2003 (zootechnical additives, coccidiostats and histomonostats), must include the information required in that Annex.
30. For premixtures, the word "PREMIXTURE" (in capital letters) and the carrier substance must also be on the label.

### CONTAINER/PACKAGES

31. Additives, premixtures and feedingstuffs must be marketed in packages or containers which must be closed in such a way that the fastener is damaged on opening and cannot be re-used. This applies to the marketing of bulk packages

## MEDICATED FEEDINGSTUFFS AND SPECIFIED FEED ADDITIVES

and containers as well as smaller packages and relevant documentation should accompany the bulk. This requirement is to ensure that any possible contamination after manufacture is easily visible.

### RECORD KEEPING

32. All manufacturers and distributors must retain their records for 5 years. In order to comply with the Regulations, all signatures and records can be made and stored electronically. This includes signatures for prescriptions.
33. The records must be stored in such a way that they may be made available immediately on request by an Inspector acting on behalf of the Secretary of State for the Department for Environment, Food and Rural Affairs. For further information on record keeping, see VMG Note 16: *Record-Keeping Requirements for Veterinary Medicinal Products*.

### IMPORTATION OF MEDICATED FEEDINGSTUFFS FROM MEMBER STATES

34. Where a medicated feedingstuff is imported from another EU Member State, it must have been manufactured in accordance with the provisions of Council Directive 90/167/EEC and Regulation (EC) No. 183/2005. It also must contain a VMP that has the same quantitative and qualitative composition as a VMP authorised in the UK.

### IMPORTATION FROM THIRD COUNTRIES

35. Feed business operators may not import medicated feedingstuffs from third countries.
36. Feed business operators may import feedingstuffs containing specified feed additives, but only in accordance with certain conditions. These are that the relevant third country appears on a list of such countries from which imports of feed are permitted and the establishment producing the feed is included on a list maintained by the relevant third country. The feed must satisfy, or be equivalent to, the required standards of safety, quality and efficacy that feed produced in the EU must meet. Further information can be found in Article 23 of Regulation (EC) 183/2005.

### IMPORTATION OF VETERINARY MEDICINAL PRODUCT FOR EXPORT ONLY

37. A manufacturer of premixture or feedingstuffs who imports a veterinary medicinal product authorised in another member State or third country for the purpose of incorporating it into premixture or feedingstuffs for export only does not commit

an offence of importation or possession of an unauthorised veterinary medicinal product.

However, it is an offence to place that premixture or feedingstuff on the market in the United Kingdom once the veterinary medicinal product has been incorporated into it.

### DISPOSAL OF FEED PRODUCTS

38. The Environment Agency is responsible for the Regulations relating to disposal of feed products. Guidance is available on their website at [www.environment-agency.gov.uk](http://www.environment-agency.gov.uk), or you may contact them on 08708 506506. Additionally, your local Waste Regulation Authority can advise on the safe disposal of any unused product and empty containers. It is essential that any disposal be dealt with in accordance with the environmental legislation.

### POSSESSION

39. It is an offence to possess a VMP, a feed additive, a premixture containing either of these, or a feedingstuff containing either of these, except in accordance with the Regulations. This only applies, however, to possession of any such products intended for placing on the market within the UK and does not apply to any that are intended for export to third countries.

### NON-COMPLIANCE

40. Where an inspection identifies a non-compliance with the Regulations in the feed business operator's operations, an Improvement Notice may be issued which will bring the deficiency to the attention of the operator. Under an Improvement Notice the operator must take the appropriate remedial action. Failure to comply with an Improvement Notice is an offence and could lead to legal action, including prosecution, being considered. Persistent infringement of the Regulations could also lead to suspension or withdrawal of the approval of the feed business operator. For further information on Improvement Notices, see VMG Note 12: *Improvement and Seizure Notices*.
41. If an Improvement Notice is served, the fee for any subsequent inspection necessary as a result of the notice is the full economic cost of the inspection payable by the person on whom the notice was served.

### FURTHER INFORMATION

42. Further information is available from the Veterinary Medicines Directorate, Woodham Lane, New Haw, Addlestone, Surrey KT15 3LS  
Tel: +44 (0)1932 336911; Fax: +44 (0)1932 336618; or E-mail:

## MEDICATED FEEDINGSTUFFS AND SPECIFIED FEED ADDITIVES

[VMGNotes@vmd.defra.gsi.gov.uk](mailto:VMGNotes@vmd.defra.gsi.gov.uk). Veterinary Medicines Guidance Notes and other information, including details of VMD contacts, are available on the VMD website: [www.vmd.gov.uk](http://www.vmd.gov.uk).

# **ANNEX A**

**ANNEX II OF EU REGULATION  
183/2005**

### ANNEX A - ANNEX II OF EU REGULATION 183/2005

#### REQUIREMENTS FOR FEED BUSINESSES OTHER THAN AT THE LEVEL OF PRIMARY PRODUCTION OF FEED REFERRED TO IN ARTICLE 5(1)

##### FACILITIES AND EQUIPMENT

1. Feed processing and storage facilities, equipment, containers, crates, vehicles and their immediate surroundings shall be kept clean, and effective pest control programmes shall be implemented.
2. The layout, design, construction and size of the facilities and equipment shall:
  - (a) permit adequate cleaning and/or disinfection;
  - (b) be such as to minimise the risk of error and to avoid contamination, cross-contamination and any adverse effects generally on the safety and quality of the products. Machinery coming into contact with feed shall be dried following any wet cleaning process.
3. Facilities and equipment to be used for mixing and/or manufacturing operations shall undergo appropriate and regular checks, in accordance with written procedures pre-established by the manufacturer for the products.
  - (a) All scales and metering devices used in the manufacture of feeds shall be appropriate for the range of weights or volumes to be measured and shall be tested for accuracy regularly.
  - (b) All mixers used in the manufacture of feeds shall be appropriate for the range of weights or volumes being mixed, and shall be capable of manufacturing suitable homogeneous mixtures and homogeneous dilutions. Operators shall demonstrate the effectiveness of mixers with regard to homogeneity.
4. Facilities must have adequate natural and/or artificial lighting.
5. Drainage facilities must be adequate for the purpose intended; they must be designed and constructed to avoid the risk of contamination of feedingstuffs.
6. Water used in feed manufacture shall be of suitable quality for animals; the conduits for water shall be of an inert nature.
7. Sewage, waste and rainwater shall be disposed of in a manner which ensures that equipment and the safety and quality of feed is not affected. Spoilage and dust shall be controlled to prevent pest invasion.
8. Windows and other openings must, where necessary, be proofed against pests. Doors must be close-fitting and proofed against pests when closed.
9. Where necessary, ceilings and overhead fixtures must be designed, constructed and finished to prevent the accumulation of dirt and to reduce condensation, the growth of undesirable moulds, and the shedding of particles that can affect the safety and quality of feed.

### **PERSONNEL**

Feed businesses must have sufficient staff possessing the skills and qualifications necessary for the manufacture of the products concerned. An organisation chart setting out the qualifications (e.g. diplomas, professional experience) and responsibilities of the supervisory staff must be drawn up and made available to the competent authorities responsible for inspection.

All the staff must be informed clearly in writing of their duties, responsibilities and powers, especially when any change is made, in such a way as to obtain the desired product quality.

### **PRODUCTION**

1. A qualified person responsible for production must be designated.
2. Feed business operators must ensure that the different stages of production are carried out according to pre-established written procedures and instructions aimed at defining, checking and mastering the critical points in the manufacturing process.
3. Technical or organisation measures must be taken to avoid or minimise, as necessary, any cross-contamination and errors. There must be sufficient and appropriate means of carrying out checks in the course of manufacture.
4. The presence of prohibited feed, undesirable substances and other contaminants in relation to human or animal health shall be monitored and appropriate control strategies to minimise the risk shall be put in place.
5. Waste and materials not suitable as feed should be isolated and identified. Any such materials containing hazardous levels of veterinary drugs, contaminants or other hazards shall be disposed of in an appropriate way and not used as feed.
6. Feed business operators shall take adequate measures to ensure effective tracing of the products.

### **QUALITY CONTROL**

1. Where appropriate, a qualified person responsible for quality control must be designated.
2. Feed businesses must, as part of a quality control system, have access to a laboratory with adequate staff and equipment.
3. A quality control plan must be drawn up in writing and implemented to include, in particular, checks on the critical points in the manufacturing process, sampling procedures and frequencies, methods of analysis and their frequency, compliance with the specifications – and the destination in the event of non-compliance – from processed materials to final products.

4. Documentation relating to the raw materials used in final products must be kept by the manufacturer in order to ensure traceability. Such documentation must be available to the competent authorities for a period appropriate for the use to which the products are placed on the market. In addition, samples of ingredients and of each batch of products manufactured and placed on the market or of each specific portion of production (in the case of continuous production), must be taken in sufficient quantity using a procedure pre-established by the manufacturer and be retained, in order to ensure traceability (on a regular basis in the case of manufacture solely for the manufacturer's own needs). The samples must be sealed and labelled for easy identification; they must be stored under conditions which prevent any abnormal change in the composition of the sample or any adulteration. They must be kept at the disposal of the competent authorities for a period appropriate to the use for which the feed is placed on the market. In the case of feedingstuffs for animals not kept for food production, the manufacturer of the feedingstuff must only keep samples of the finished product.

### **STORAGE AND TRANSPORT**

1. Processed feeds shall be separated from unprocessed feed materials and additives, in order to avoid any cross-contamination of the processed feed; proper packaging materials shall be used.
2. Feeds shall be stored and transported in suitable containers. They shall be stored in places designed, adapted and maintained in order to ensure good storage conditions, to which only persons authorised by the feed business operators have access.
3. Feeds shall be stored and transported in such a way as to be easily identifiable, in order to avoid any confusion or cross-contamination and to prevent deterioration.
4. Containers and equipment used for the transport, storage, conveying, handling and weighing of feed shall be kept clean. Cleaning programmes shall be introduced, and traces of detergents and disinfectants shall be minimised.
5. Any spoilage shall be minimised and kept under control to reduce pest invasion.
6. Where appropriate, temperatures shall be kept as low as possible to avoid condensation and spoilage.

### RECORD-KEEPING

1. All feed business operators, including those who act solely as traders without ever holding the product in their facilities, shall keep in a register, relevant data comprising details of purchase, production and sales for effective tracing from receipt to delivery, including export to the final destination.
2. Feed business operators, except those who act solely as dealers without ever holding the product in their facilities, shall keep in a register:

- (a) Documentation relating to the manufacturing process and controls.

Feed businesses must have a system of documentation designed to define and ensure mastery of the critical points in the manufacturing process and to establish and implement a quality control plan. They must keep the results of the relevant controls. This set of documents must be kept so that it is possible to trace the manufacturing history of each batch of products put into circulation and to establish responsibility, if complaints arise.

- (b) Documentation relating to traceability, in particular:

- (i) for feed additives:

- the nature and quantity of the additives produced, the respective dates of manufacture and, where appropriate, the number of the batch or of the specific portion of production, in the case of continuous manufacture;
- the name and address of the establishment to which the additives were delivered, the nature and quantity of the additives delivered and, where appropriate, the number of the batch or of the specific portion of production, in the case of continuous manufacture.

- (ii) for products covered by Directive 82/471/EEC:

- the nature of the products and the quantity produced, the respective dates of manufacture and, where appropriate, the number of the batch or of the specific portion of production, in the case of continuous manufacture;
- the name and address of the establishments or users (establishments or farmers) to whom these products have been delivered, together with details of the nature and quantity of the products delivered and, where appropriate, the number of the batch or of the specific portion of production, in the case of continuous manufacture.

(iii) for premixtures:

- the name and address of the manufacturers or suppliers of additives, the nature and quantity of the additives used and, where appropriate, the number of the batch or of the specific portion of production, in the case of continuous manufacture;
- the date of manufacture of the premixture and the batch number where appropriate;
- the name and address of the establishment to which the premixture is delivered, the delivery date, the nature and quantity of the premixture delivered, and the batch number where appropriate.

(iv) for compound feedingstuffs/feed materials:

- the name and address of additive/premixture manufacturers or suppliers, the nature and quantity of the premixture used, with the batch number where appropriate;
- the name and address of the suppliers of the feed materials and complementary feeds, and the delivery date;
- the type, quantity and formulation of the compound feed;
- the nature and quantity of feed materials or compound feedingstuffs manufactured, together with the date of manufacture, and the name and address of the buyer (e.g. farmer, other feed business operators).

### COMPLAINTS AND PRODUCT RECALL

1. Feed business operators shall implement a system for registering and processing complaints.
2. They shall put in place, where this proves necessary, a system for the prompt recall of products in the distribution network. They shall define by means of written procedures the destination of any recalled products, and before such products are put back into circulation, they must undergo a quality-control reassessment.

# ANNEX B

**WHO CAN SELL WHAT TO WHOM**  
SUBJECT TO THE BUSINESS HAVING BEEN APPROVED WITHIN THAT CATEGORY

# MEDICATED FEEDINGSTUFFS AND SPECIFIED FEED ADDITIVES

## IN FEED VETERINARY MEDICINAL PRODUCTS (VMPs)

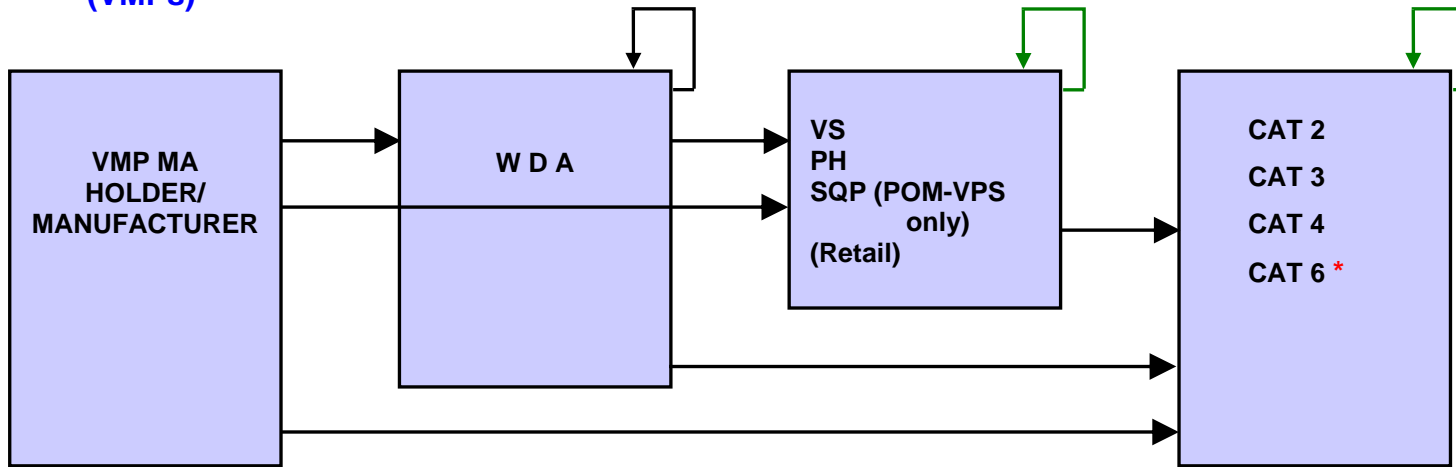

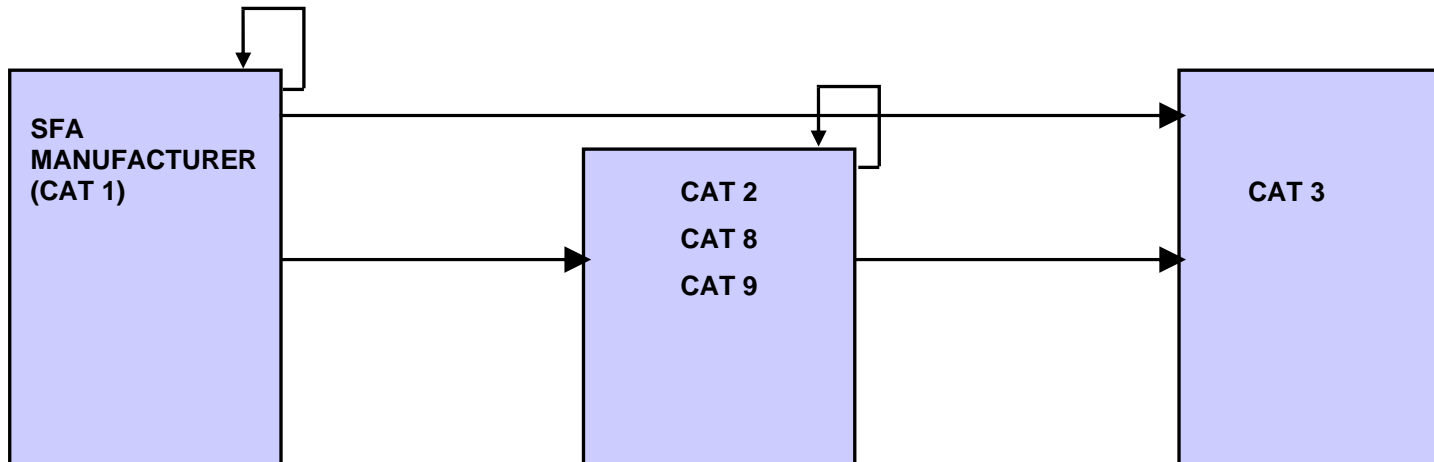

## SPECIFIED FEED ADDITIVES (SFAs)



### DEFINITIONS

- MAH** Marketing Authorisation Holder
- CAT 1** Specified Feed Additive Manufacturer
- CAT 2** Manufacturer of SFA and Medicated Premixtures
- CAT 3** Compound Feed Manufacturer (incorporating VMPs and SFAs or premixtures containing such products at any rate)
- CAT 4** Compound Feed Manufacturer (incorporating VMPs or premixtures containing VMPs at a rate of at least 2kg per tonne)
- CAT 5** Compound Feed Manufacturer (incorporating SFAs via premixtures)
- CAT 6** On Farm Manufacturer for own use (incorporating VMPs or premixtures containing VMPs at a rate of at least 2kg per tonne)
- CAT 7** On Farm Manufacturer for own use (incorporating SFAs via premixtures)
- CAT 8** Distributor – who handles/stores product
- CAT 9** Distributor – who trades but does not hold products on premises
- SQP** Suitably Qualified Person
- WDA** Wholesale Dealer
- VS** Veterinary Surgeon
- PH** Pharmacist
- \*** To a valid MFS prescription

 WHOLESALE – one can supply another person in the same category

 The green arrow means an approved premixture or feedingstuffs manufacturer may wholesale supply to another approved premixture or feedingstuffs manufacturer, provided that in any one year the amount supplied by the manufacturer does not exceed 5% of value of turnover.

# VETERINARY MEDICINES GUIDANCE NOTE 22

## PREMIXTURES CONTAINING VMPs and/or SFAs

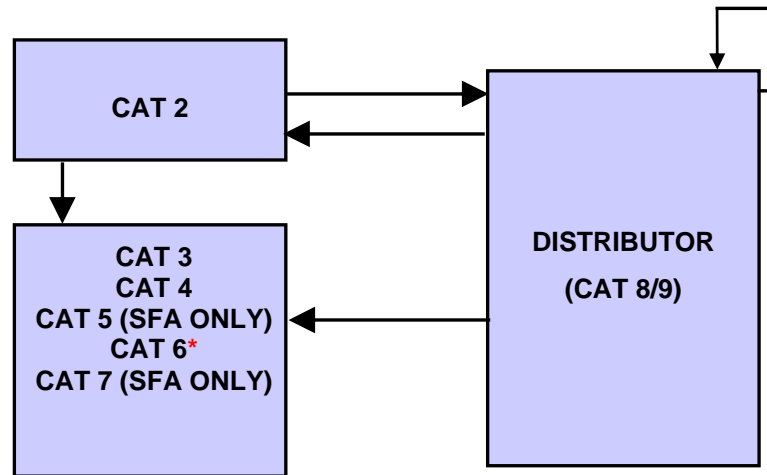

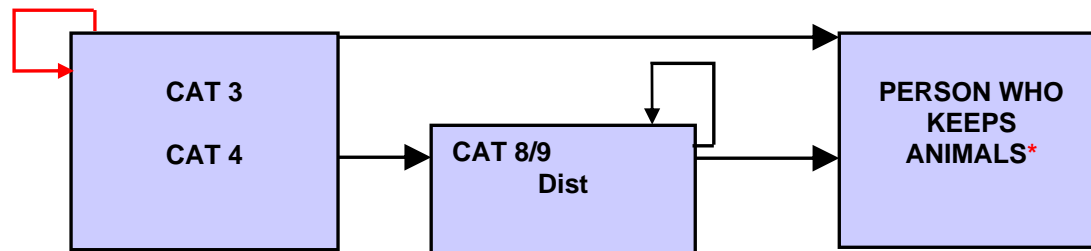

## FINAL MEDICATED FEEDINGSTUFFS



### DEFINITIONS

<b>MAH</b>	Marketing Authorisation Holder
<b>CAT 1</b>	Specified Feed Additive Manufacturer
<b>CAT 2</b>	Manufacturer of SFA and Medicated Premixtures
<b>CAT 3</b>	Compound Feed Manufacturer <i>(incorporating VMPs or SFAs or premixtures containing such products at any rate)</i>
<b>CAT 4</b>	Compound Feed Manufacturer <i>(incorporating VMPs or premixtures containing VMPs at a rate of at least 2kg per tonne)</i>
<b>CAT 5</b>	Compound Feed Manufacturer <i>(incorporating SFAs via premixtures)</i>
<b>CAT 6</b>	On Farm Manufacturer for own use <i>(incorporating VMPs or premixtures containing VMPs at a rate of at least 2kg per tonne)</i>
<b>CAT 7</b>	On Farm Manufacturer for own use <i>(incorporating SFAs via premixtures)</i>
<b>CAT 8</b>	Distributor – who handles/stores product
<b>CAT 9</b>	Distributor – who trades but does not hold products on premises
<b>SQP</b>	Suitably Qualified Person
<b>WDA</b>	Wholesale Dealer
<b>VS</b>	Veterinary Surgeon
<b>PH</b>	Pharmacist

- \* To a valid MFS prescription
-  WHOLESALE – one can supply another person in the same category
-  Toll manufacturers only (see paragraph 15)



# VETERINARY MEDICINES GUIDANCE NOTE

**VETERINARY MEDICINES DIRECTORATE**

**WOODHAM LANE, NEW HAW, ADDLESTONE, SURREY KT15 3LS**

Telephone: +44 (0)1932 336911 Fax +44 (0)1932 336618

E-mail [VMGNotes@vmd.defra.gsi.gov.uk](mailto:VMGNotes@vmd.defra.gsi.gov.uk) [www.vmd.gov.uk](http://www.vmd.gov.uk)



ASSURING THE SAFETY, QUALITY AND EFFICACY  
OF VETERINARY MEDICINES